

Sentry MPS



QUALITY POWER SUPPLY

SENTRY MPS is an on-line double conversion UPS (VFI SS 111 in accordance with IEC EN 62040-3) with a transformer isolated inverter. With a compact footprint and high power quality output, SENTRY MPS is designed to protect "mission critical" applications including data processing, telecommunications, industrial processes, security and electro-medical systems. SENTRY MPS is available in four ratings 100, 120, 160, 200, 250, 300 and 400 KVA, each of these are offered in four versions with different input harmonic distortion and power factor for better matching the market requirements:

- MPS,
- MPS LH,
- MPS Plus,
- MPS Sinus.

BATTERY CARE SYSTEM: MAXIMUM LIFETIME POTENTIAL

Traditionally, when a mains supply is present the UPS charges its batteries. Battery power is used for the inverter should the input supply fail. Efficient battery management and care is therefore essential to the overall performance of the UPS in an emergency. The SENTRY MPS Battery Care System consists of a range of features designed to provide optimum performance and enhanced operating life:

- Dual level charging regime to optimise recharge currents and lower recharge times;
- Temperature compensation and deep discharge protection to reduce overall battery aging;
- Charge blocking system to reduce electrolyte consumption and lengthen the life of VRLA batteries;
- Predictive battery testing to spot potential battery deterioration and failure.

SENTRY MPS is also compatible with different battery technologies: open-vase lead acid and AGM and Gel VRLA, NiCd.

MINIMUM IMPACT ON SUPPLIES - EASY SOURCE

SENTRY MPS technology removes the problems of over sizing downstream power sources, whilst improving load power factors and current harmonics. The UPS features the latest input current absorption techniques including progressive rectifier start-up and the option to reduce battery charging currents. These features make SENTRY MPS one of the most generator compatible and environmentally friendly UPS available.



FLEXIBILITY

SENTRY MPS is suitable for a wide range of applications including IT and the most demanding industrial environments. With a broad of accessories and options, complex configurations and system architectures can be achieved to guarantee maximum power availability and the option to add new UPS without interruption to existing users. Using the AROS UPS Group Synchroniser (USG) and Parallel Systems Joiner (PSJ) sophisticated inter group parallel and redundant systems can be achieved to provide the highest possible levels of resilience and availability.

EASE OF INSTALLATION

SENTRY MPS has a small footprint (only 0,64 sqm for 200kVA). Front access to internal assemblies and top panel ventilation make space allocation within confined data processing or plant rooms easy. SENTRY MPS can be placed against a wall as there is no requirement for rear or side panel access for maintenance or ventilation.

ADVANCED COMMUNICATION

- Compatible with TeleGuard for remote maintenance
- Advanced, multi-platform communication, for all operating systems and network environments: Watch&Save supervision and shut-down software included, with SNMP agent, for Windows 95, 98, NT 4.0, Me, 2000, 2003, XP, Mac OS 9.x, X, Linux, Novell operating systems. The UPS is supplied with a cable for direct connection to the PC (Plug and Play)
- RS232 double serial port
- Slot for installation of the mains adapter; EPO contact (Emergency Switching Device) for switching off the UPS with a remote emergency switch
- Remote mimic panel (LED or LCD)

APPLICATIONS

- Servers
- Local Area Network (LAN)
- Data centers
- Telecommunications
- Industrial equipment
- Electro-medical equipment

OPTIONS

- Input Isolation transformer
- UPS Group Synchroniser (UGS)
- Dynamic DUAL BUS SYSTEM (PSJ)
- Interface for generator
- LED remote status panel
- LCD based remote control panel
- Empty battery cabinets for prolonged runtime



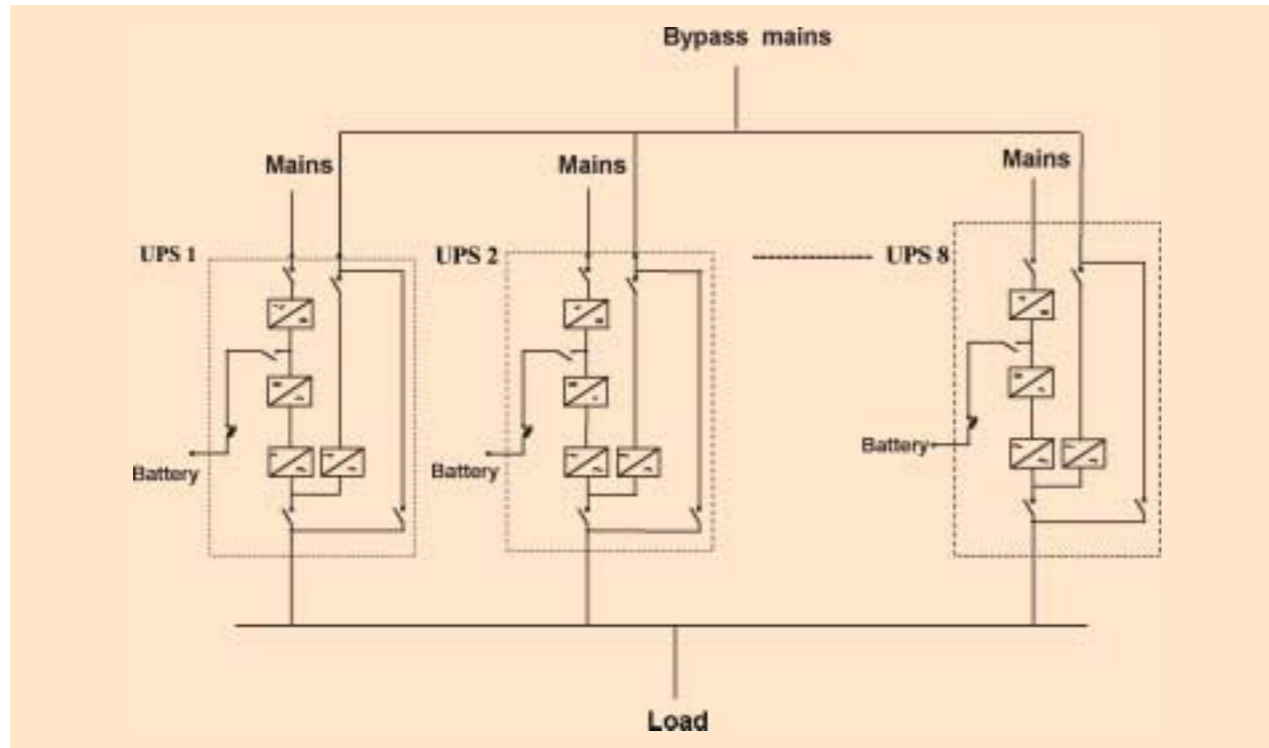

Fig 1 - Block diagram UPS in parallel up to 8 units

EXPANDABILITY

The units can be connected in parallel up to 8 units to increase power availability or redundancy. The single module or the system can be expanded any time to suit power requirements without influencing the initial investment. Thanks to the peculiarity of the "Hot System Expansion" feature, the additional unit can be connected in parallel while the other units are on-line and supplying regular power to the load. The new UPS is on-line and will be set up automatically.



DUAL BUS SYSTEM

The Dual Bus System powers the priority loads from two independent sources.

This configuration increases the redundancy and availability level of a multi-module configuration. Each bus may consist of a single module or up to

8 modules in parallel, kept in synchrony by the UGS (UPS Group Synchroniser).

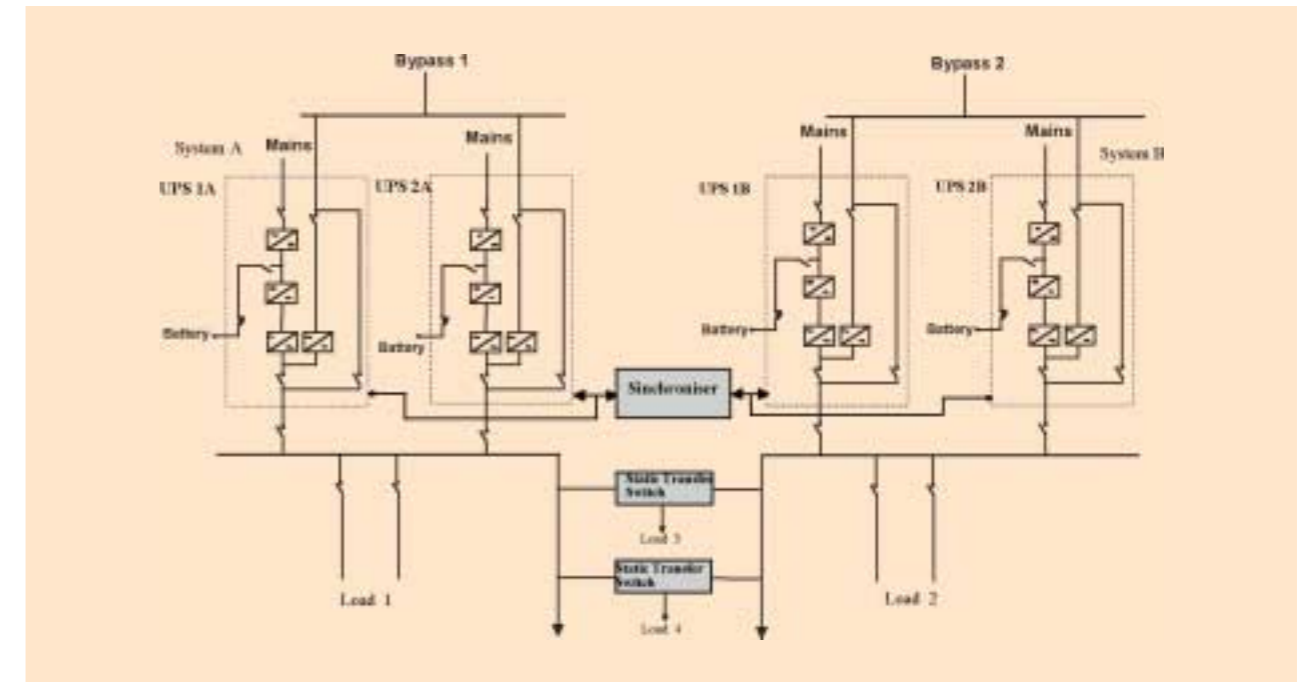

Fig. 2 - Dual bus System

DYNAMIC DUAL BUS SYSTEM

Two independent systems set in Dual Bus Configuration can be merged

together at any time for system expansion or maintenance. This provides a lot of flexibility in your

installation in case of maintenance or when it is necessary to change the redundancy level of both systems.

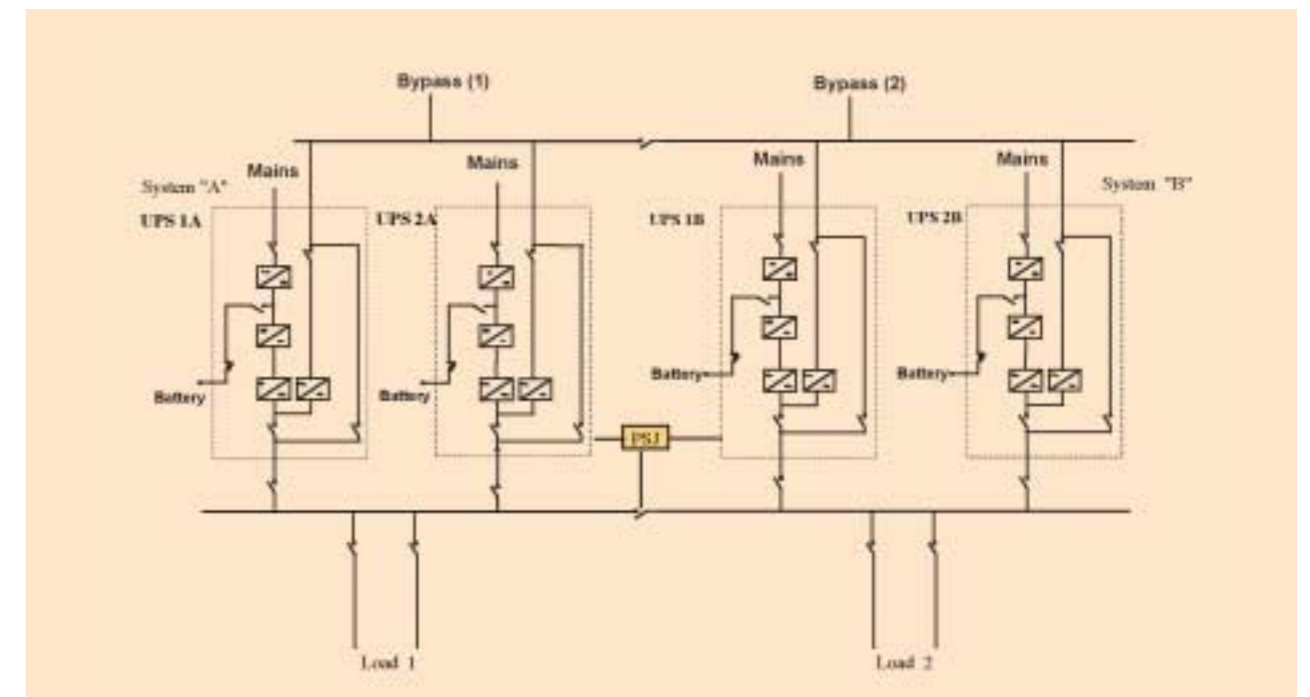

Fig. 3 - Dynamic Dual Bus System

Sentry MPS

Technical data

| Models | MPS 100 | MPS 120 | MPS 160 | MPS 200 |
|--|--|---------|---------|---------|
| Power (kVA) | 100 | 120 | 160 | 200 |
| Input | MPS 100 | MPS 120 | MPS 160 | MPS 200 |
| Nominal voltage | 380 - 400 - 415 Vac three-phase | | | |
| Voltage tolerance | 400 V ± 20% | | | |
| Frequency | 45 ÷ 65 Hz | | | |
| Power factor | >0.95 in the Sinus version | | | |
| Current harmonic distortion | <3% in the Sinus version | | | |
| Soft start | 0 ÷ 100% in 120" configurable | | | |
| Permitted frequency tolerance | ± 2% (selectable from ± 1% to ± 5% from the front panel) | | | |
| Standard features | Back Feed protection; separable bypass line | | | |
| Battery | MPS 100 | MPS 120 | MPS 160 | MPS 200 |
| Type | Lead, open vase acid and VRLA, AGM / GEL; NiCd | | | |
| AC ripple current | Zero | | | |
| Temperature compensation | -0,5 Vx °C | | | |
| Output | MPS 100 | MPS 120 | MPS 160 | MPS 200 |
| Rated power (kVA) | 100 | 120 | 160 | 200 |
| Active power with load PF from 0,8 ind. to 0,9 cap. (kW) | 80 | 96 | 128 | 160 |
| Number of phases | 3 + N | | | |
| Nominal voltage | 380 - 400 - 415Vac three-phase + N | | | |
| Static stability | ± 1% | | | |
| Dynamic stability | ± 5% in 10 msec. | | | |
| Voltage distortion with linear load | <1% | | | |
| Voltage distortion with non linear load | <3% | | | |
| Frequency | 50 or 60 Hz configurable | | | |
| Waveform | Sinusoidal | | | |
| Peak factor | 3:1 | | | |
| Overload | 110% for 60'; 125% for 10'; 150% for 1' | | | |
| System | MPS 100 | MPS 120 | MPS 160 | MPS 200 |
| Remote signalling | Voltage-free contacts (configurable) | | | |
| Remote commands | EPO and bypass | | | |
| Communication | Double RS232 + remote contacts + 2 communication interface slots | | | |
| Efficiency | Up to 94% | | | |
| Dimensions (wdh) (mm) | 800x800x1900 (base version) | | | |
| Weight (kg) | 600 | 650 | 750 | 800 |
| Noise level | 63 ÷ 68 dBA a 1 m | | | |
| Operating temperature | 0 °C / +40 °C | | | |
| Relative humidity | <95% non condensing | | | |
| Protection degree | IP20 | | | |
| Colour | Light grey (RAL 7035) | | | |
| Compliance | Directives EEC 73/23 - 93/68 - 89/336 Safety IEC EN 62040-1; EMC IEC EN 62040-2; Performance IEC EN 62040-3 | | | |
| Classification as per IEC 62040-3 | (Voltage Frequency Independent) VFI - SS - 111 | | | |

Sentry MPS

Technical data

| Models | MPS 250 | MPS 300 | MPS 400 |
|--|--|---------|----------------|
| Power (kVA) | 250 | 300 | 400 |
| Input | MPS 250 | MPS 300 | MPS 400 |
| Nominal voltage | 380 - 400 - 415 Vac three-phase | | |
| Voltage tolerance | 400 V ± 20% | | |
| Frequency | 45 ÷ 65 Hz | | |
| Power factor | >0.95 in the Sinus version | | |
| Current harmonic distortion | <3% in the Sinus version | | |
| Soft start | 0 ÷ 100% in 120" configurable | | |
| Permitted frequency tolerance | ± 2% (selectable from ± 1% to ± 5% from the front panel) | | |
| Standard features | Back Feed protection; separable bypass line | | |
| Battery | MPS 250 | MPS 300 | MPS 400 |
| Type | Lead, open vase acid and VRLA, AGM / GEL; NiCd | | |
| AC ripple current | Zero | | |
| Temperature compensation | -0,5 Vx °C | | |
| Output | MPS 250 | MPS 300 | MPS 400 |
| Rated power (kVA) | 250 | 300 | 400 |
| Active power with load PF from 0,8 ind. to 0,9 cap. (kW) | 200 | 240 | 320 |
| Number of phases | 3 + N | | |
| Nominal voltage | 380 - 400 - 415 Vac three-phase + N | | |
| Static stability | ± 1% | | |
| Dynamic stability | ± 5% in 10 msec. | | |
| Voltage distortion with linear load | <1% | | |
| Voltage distortion with non linear load | <3% | | |
| Frequency | 50 or 60 Hz configurable | | |
| Waveform | Sinusoidal | | |
| Peak factor | 3:1 | | |
| Overload | 110% for 60'; 125% for 10'; 150% for 1' | | |
| System | MPS 250 | MPS 300 | MPS 400 |
| Remote signalling | Voltage-free contacts (configurable) | | |
| Remote commands | EPO and bypass | | |
| Communication | Double RS232 + remote contacts + 2 communication interface slots | | |
| Efficiency | Up to 94% | | |
| Dimensions (wdh) (mm) | 850x1630x1900 | | 1000x1630x1900 |
| Weight (kg) | 2200 | 2200 | 2600 |
| Noise level | 70 dBA a 1 m | | |
| Operating temperature | 0 °C / +40 °C | | |
| Relative humidity | <95% non condensing | | |
| Protection degree | IP20 | | |
| Colour | Light grey (RAL 7035) | | |
| Compliance | Directives EEC 73/23 - 93/68 - 89/336 Safety IEC EN 62040-1; EMC IEC EN 62040-2; Performance IEC EN 62040-3 | | |
| Classification as per IEC 62040-3 | (Voltage Frequency Independent) VFI - SS - 111 | | |